

DISPLAY | Cabinet Displays

REFRIGERATED SHOWCASES UPRIGHT ▶ WHITE

RC 98



GAS R600a	M2 -1°C +7°C	C ENERGY CLASS	4 +30°C/55RH
LED		FAN	

DETAILS

Door handle	Inner vertical LED light	Digital Thermostat
-------------	--------------------------	--------------------

GENERAL FEATURES

- 98 Lt. Upright refrigerated showcase (White Color)
- Flat glass with white frame and plastic basement
- Ventilated Cooling
- Automatic compressor cycle defrost
- Digital display control
- Interior LED light
- Toughened safety glass
- Adjustable shelves (N.4 shelf)
- N.4 fix support assembled under the basement
- Energy efficiency class: C

TECHNICAL SPECIFICATIONS

Capacity	98 L
Temperature	M2 (-1°C-+7°C)
Consumption	3.839 kWh/24h
Rated Power	180 W
Noise level	46 dB(A)
Net Weight	38 Kg
Gross Weight	46 Kg
External Dimensions (WxDxH mm)	428x386x1110
Internal Dimensions (WxDxH mm)	400x370x750
Packaging dimensions (WxDxH mm)	475x432x1300
Loading quantities 20'/40'/40'HQ	126/252/252

PRODUCT DIMENSIONS

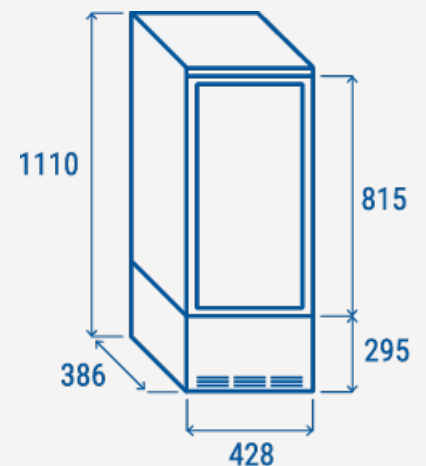

CERTIFICATION

CE RoHS



COOL HEAD EUROPE
We make the world a cooler place



www.coolheadeurope.com